

BASIC ARKANSAS INTESTATE SUCCESSION, RIGHTS OF SURVIVING SPOUSES, AND RELATED CURATIVE TECHNIQUES FOR LAWYERS AND LANDMEN

BY

J. MARK ROBINETTE JR.¹

I. Introduction

Mineral interests may lay dormant for decades before becoming productive. In the interim, however, the owners of these interests do not lay dormant. They live long lives, marry, have children, and eventually, they die. Some of these persons have well-laid estate plans, know the nature and extent of their property, and upon their departure to the hereafter, leave their affairs in meticulous order with no question of who is entitled to what and where. Others depart this life leaving little more than a treasure map and their descendants. Generations and many lines of persons descended from one severed mineral owner repeat the cycle of life—marriage, children, and death with or without consideration for what happens to their property upon their passing. Over many generations with such variations in the handling of final affairs among members of a family, the ownership of the original mineral owner's interest today can resemble a bowl of spaghetti.

When confronted with such fragmented and splintered ownership, a lawyer or landman can untangle a family history and determine the true owners of a severed interest by simply knowing the basics of intestate succession, the rights of surviving spouses, and how to cure title issues generated by the former. These course materials are intended as a refresher course for lawyers and as a general guide for landmen. This course will begin with an overview of intestate succession in Arkansas. Next, this course will examine the dower rights of surviving spouses to the real estate of the intestate under Arkansas law. Finally, this course will suggest curative techniques for problems encountered with intestacy.

II. Intestate Succession

A. Identification of Intestates

To begin, it is necessary to identify whether someone is, in fact, an intestate. One is generally said to be intestate when one dies without a will.² This, however, is an oversimplified definition of intestacy because intestacy can encompass more than just those dying without a will. In Arkansas, one is intestate for failing to probate the will within the 5 year statute of limitation,³ not disposing of all property in the will,⁴ leaving a child out of a will,⁵ and as to nonresidents with valid probates in other

¹ Perkins & Trotter, PLLC, P.O. Box 251618, Little Rock, AR 72225-1618; mrobinette@perkinstrotter.com

² BLACK'S LAW DICTIONARY 369 (2nd Pocket ed. 2001).

³ See ARK. CODE ANN. § 28-40-103(a). This applies to Arkansas residents only.

⁴ *Id.* at § 28-26-103

⁵ *Id.* at § 28-39-407

states, they are intestate relative to their Arkansas real property until somebody conducts an ancillary probate in Arkansas.⁶

These are general statements, and there are some important finer points about the statute of limitations to probate a will to address. Prior to 1949, there was no statute of limitation for probating a will. With the passage of Act 140 of 1949, the legislature imposed a 5 year statute of limitations on all wills, both of residents and non-residents. The legislature amended the law with Act 166 of 1963, which added the provision in the current that allows probate of the wills of non-residents at any time if already done so in their home jurisdiction. Cases interpreting the effect of these statutes create irreconcilable problems. It is clear that non-residents who died between 1949 and 1963 with a valid probate in their jurisdiction but no Arkansas probate are intestate with little hope of having their final wishes respected.⁷ What happens to the unprobated will of a non-resident who died prior to the 1949 statute change is less certain. There is a 1951 case that allowed, in 1950, the probate of the will of a resident that died in 1935.⁸ The court held that the 1949 statute change was prospective only and that the law applicable at the time of the deceased's death (1935) applied.⁹ In 1961, the court, apparently oblivious to its prior holding, held that the will of a non-resident who died in 1923 offered for probate in 1959 was subject to the 1949 statute change (that is, the law had retrospective application) because the purpose of the law change was to clear titles.¹⁰ It is not possible to conclusively determine that someone who died prior to 1949 with an unprobated will is an intestate. The only way to know for certain is to attempt to probate the will. Most likely, if there is no party that wishes to object, the court will accept the will into probate.

B. Fundamentals of Intestate Succession

Once it is established that a person is an intestate, title passes to the intestate's heir under the applicable Table of Descents.¹¹ Tables of Descents are statutory declarations directing the descent of the property of the intestate. The law of intestate succession in effect at the time of the intestate's death governs.¹² Prior to discussing Arkansas Tables of Descents, the reader should be familiar with some basic terminology and principles that guide the flow of an intestate's property through a Table of Descents.

The first concept of intestacy is consanguinity. This term is a Latin-rooted word meaning "with blood." The English usage of the word essentially means "related by blood." At common law, consanguinity was the sole means to identify an intestate's heirs. A common teaching device to understand consanguinity is the Table of Consanguinity, pictured below.

⁶ See *Id.* at § 28-9-203(c)(1) and *Cooper v. Tosco Corporation*, 272 Ark. 294, 613 S.W.2d 831 (1981).

⁷ See *Delafield v. Lewis*, 299 Ark 50, 770 S.W.2d 659 (1989).

⁸ See *Hudson v. Hudson*, 219 Ark. 211, 242 S.W.2d 154 (1951).

⁹ See *Sims v. Schavey*, 234 Ark. 166, 351 S.W.2d 145 (1961).

¹⁰ *Id.*

¹¹ ARK. CODE ANN. § 28-9-214.

¹² See *Wheeler v. Myers*, 330 Ark. 728, 956 S.W.2d 863 (1997).

Table of Consanguinity

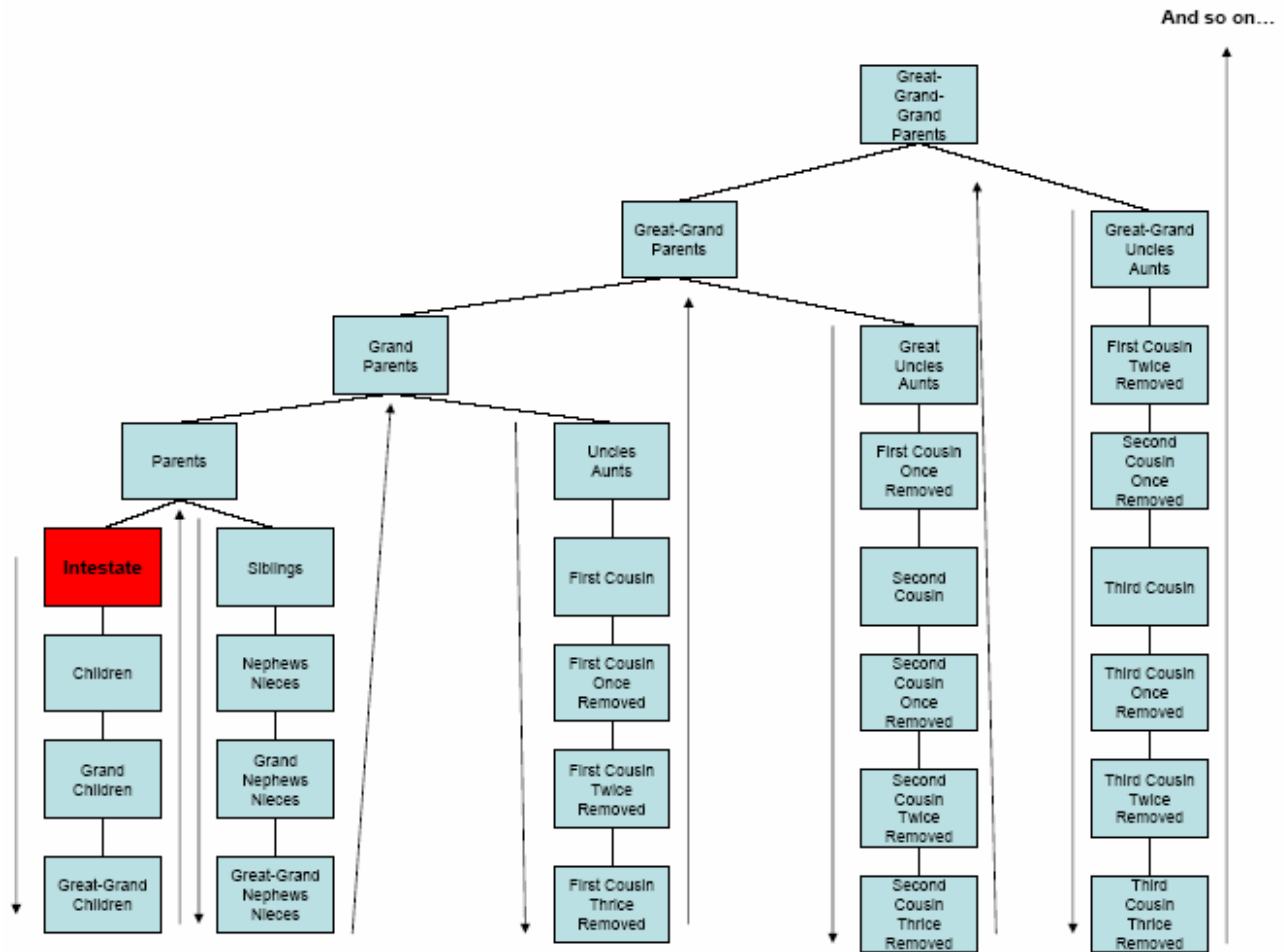

As the arrows on the table indicate, the intestate’s interest will descend down the table of consanguinity to the intestate’s children and their descendants, or “issue.” Issue is a synonym for the intestate’s children and descendants of the intestate’s children.¹³ Should the intestate have no issue, the interest ascends back to the intestate’s parents. If the parents are deceased, the intestate’s interest jumps up to the next level of consanguinity—the intestate’s siblings and their descendants. This process of moving down and up the table of consanguinity repeats until the nearest living relatives of the intestate emerge. Relatives beyond the line of an intestate’s grandparents are often called “laughing heirs” because in all likelihood, they did not personally know the intestate and “laugh all the way to the bank.”¹⁴ Many statutory schemes and the Uniform Probate Code seek to eliminate laughing heirs.¹⁵ Arkansas’s current scheme is not one of them, though it greatly reduces the already low probability of inheritance by laughing heirs by heavily favoring a surviving spouse.¹⁶

¹³ BLACK’S, *infra* note 1 at 373.

¹⁴ WILLIAM M. MCGOVERN, JR. AND SHELDON F. KURTZ, *WILLS, TRUSTS AND ESTATES INCLUDING TAXATION AND FUTURE INTERESTS* 59 (3d Edition Thomson-West 2004) (1987).

¹⁵ *See Id.*

¹⁶ *See Exhibit A, supra.* The only instance where collateral heirs are favored over the spouse in the current Arkansas scheme is where the intestate dies without issue and a spouse of less than 3 years, or if there is no surviving spouse.

Consanguinity provides a general direction of property flow, but it does not provide a means of dividing the intestate's property among the intestate's heirs. Property divides among the intestate's heirs by two legal concepts rooted in the Latin language: per capita and per stirpes. The term per capita literally means "by the person,"¹⁷ while per stirpes means "by the line."¹⁸ At common law and under Arkansas Statutes, per capita means that all members "of a class who inherit real or personal property from an intestate...related to an intestate in equal degree...will inherit the intestate's property in equal shares."¹⁹ Per stirpes inheritance at common law and under Arkansas Statutes occurs when "the intestate is predeceased by one (1) or more person who would have been entitled to inherit from the intestate had such a person survived the intestate."²⁰ To illustrate per capita inheritance, if A dies intestate with children B, C, and D surviving him, then A's property passes as follows:

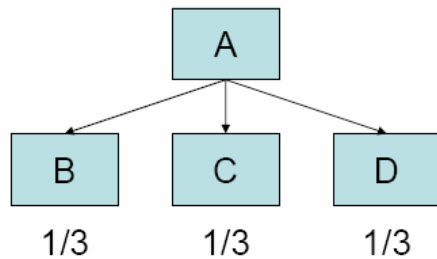

B, C, and D are members of a class who inherit real or personal property from an intestate in an equal degree, so they take their shares per capita

Now suppose that B, C, and D have a brother E who predeceased them but who left two children, F and G. In this instance, B, C, D, and E still take per capita, but E's share flows per stirpes to his children F and G, who are members of a class related in equal degree, so they take per capita. The following diagram depicts this scenario.

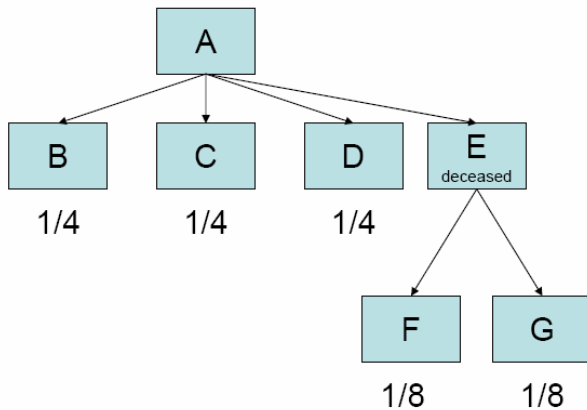

B, C, D, E are members of a class who inherit real or personal property from an intestate in an equal degree, so they take their shares per capita. F and G take from through their deceased parent per stirpes. Amongst themselves, F and G are members of the same class related to one another in equal degree, so they take per capita.

¹⁷ BLACK'S, *infra* note 1 at 522.

¹⁸ *Id.* at 526.

¹⁹ ARK. CODE ANN. § 28-9-204(1)(A).

²⁰ *Id.* at § 28-9-205(a)(1).

As final illustration of the concept, let us assume that F predeceased E and A, but left his children H, I, and J. In this case, H, I, and J take F's share per stirpes and it divides among them per capita. A depiction of this scenario follows.

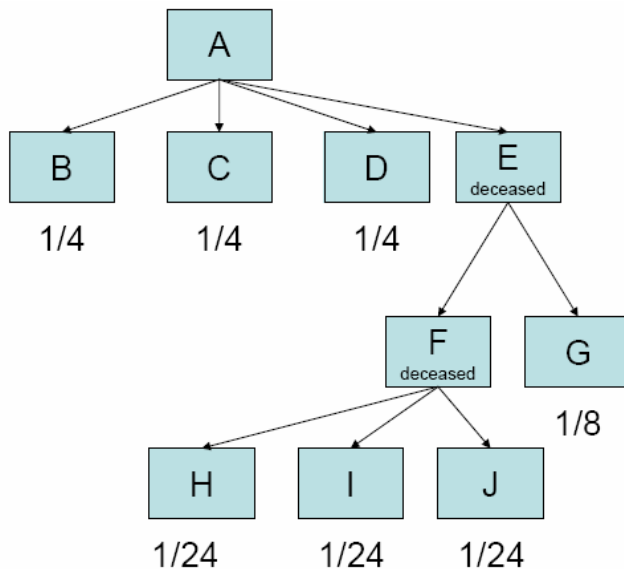

B, C, D, E are members of a class who inherit real or personal property from an intestate in an equal degree, so they take their shares per capita. F and G take from through their deceased parent per stirpes. Amongst themselves, F and G are members of the same class related to one another in equal degree, so they take per capita. H, I, and J take per stirpes through F and per capita amongst themselves.

In addition to the general concepts of consanguinity, per capita, and per stirpes, there are important miscellaneous legal principles that guide intestacy. While seeming to be a matter of common sense, the identity of an intestate's issue is sometimes a delicate matter. Naturally born²¹ and legitimate children of the deceased are always entitled to take from an intestate.²² Adopted children are also always included among a person's intestate heirs.²³ Illegitimate children, however, are treated vastly different from either of the former classes of children. In the case of a mother giving birth to an illegitimate child, that child will automatically take both from and through the mother.²⁴ That is, all property descending from the illegitimate child's mother or mother's family will go to the illegitimate child. With regard to the father of the illegitimate child's property, the illegitimate child will not take from his or her father unless the illegitimate child files a claim against the father's estate within 180 days of the father's death and meets a statutory evidentiary requirement.²⁵

²¹ A trap for the unwary with regard to natural born children is ACA § 9-9-215, effective in 1977 which provides that a final order of adoption terminates the right to inherit from a natural parent. This provision applies when the deceased dies after 1977. See *Wheeler*, 330 Ark. 728, 956 S.W.2d 863 (1997).

²² ARK. CODE ANN. § 28-1-102(a)(1).

²³ *Id.*

²⁴ *Id.* at § 28-9-209(d). This is also true of all other past Arkansas intestate schemes.

²⁵ *Id.* The statute requires an illegitimate child to present one of the following to establish paternity for purposes of inheriting from the intestate father: "A court of competent jurisdiction has established the paternity of the child...; The man has made

Another consideration of intestacy law is the distinction between ancestral property and new acquisitions. This distinction is inapplicable to the current inheritance code, but should be considered for older Arkansas intestate schemes. Ancestral property is real property that came from an intestate's ancestor "in consideration of blood and without a pecuniary equivalent" by "devise from a now dead ancestor or by deed of actual gift from a living one."²⁶ A new acquisition, also termed "non ancestral property," is property acquired by any other means.²⁷

The final miscellaneous consideration is the estate taken by intestate heirs. Under both the current inheritance code and the historical schemes, the heirs of the intestate take as tenants in common.²⁸

C. Current and Former Arkansas Tables of Descent²⁹

Due to the size of the intestacy law flow charts, they are attached and incorporated as Exhibits A-D for intestate succession applicable from 1969 to present, 1933-1959, 1959-1969, and 1894-1933, respectively.

D. Intestate Succession Hypotheticals

In all the following facts, every person who dies does so without a will, single, and without children unless so stated. For each hypothetical, use the Tables of Descent flowcharts and your title knowledge to determine the rightful heirs to SouthFork and the Ewing Estate, respectively, for the current and each former Arkansas Table of Descent.

Facts: Ellie and Jock Ewing, residents of Arkansas married for more than 3 years, have three boys: J.R., Bobby, and Gary. Jock had a dalliance with an Air Corps nurse during the war and had an illegitimate son, Ray. Ray has no proof he is Jock's son other than stories from his mother. Among the real property owned by Ellie and Jock is Southfork, which Ellie inherited as sole heir of Aaron Southworth. She and her children are the last of the Southworth line but for Ellie's first cousins John Smith who is a cousin by Ellie's father and Jackie Johnson, a cousin by Ellie's mother. The Ewing Estate was owned by the Ewing's as tenants by the entirety as a new acquisition. Other than his immediate family, Jock has one other living relative, his niece Jamie.

a written acknowledgment that he is the father of the child; The man's name appears with his written consent on the birth certificate as the father of the child; The mother and father intermarry prior to the birth of the child; The mother and putative father attempted to marry each other prior to the birth of the child by a marriage solemnized in apparent compliance with law, although the attempted marriage is or could be declared invalid; or The putative father is obligated to support the child under a written voluntary promise or by court order." This became the law by Act 1015 of 1979. For a recent examination of this statute in a quiet title decree, see *Defir v. Reed*, 103 Ark. App. 319, 2008 WL 4735543 (2008). Prior to this act, the statutes consistently required the illegitimate child of a father to marry the mother and recognize the child as his own. See A.S.A. 1947 § 61-103; Crawford and Moses § 3474 (1921); English 56:4-5. Alternatively, the child could be a product of a legally defective marriage. *Id.*

²⁶ *Webb v. Caldwell*, 128 S.W.2d 691, 694, 198 Ark. 331, 332 (1939).

²⁷ *Id.*

²⁸ ARK. CODE ANN. § 28-9-207.

²⁹ The author wishes to credit and express his gratitude to Mr. Grant M. Cox of Perkins & Trotter, PLLC for his assistance in researching the historical Arkansas Statutes.

Hypothetical #1: Jock dies tragically in the jungles of South America hunting down his latest oil prospect. A year later, Ellie dies.

Hypothetical #2: J.R., Bobby, and Gary die in a helicopter crash over south Louisiana, but Jock survives in the swamp for a few weeks before succumbing to starvation. Ellie moves on and marries Clayton Farlow. Ellie dies intestate after being married to Clayton for over 3 years.

Hypothetical #3: Digger Barnes shows up drunk at the annual Ewing Barbeque, driving his shoddy old car into Bobby, Gary, and J.R. killing them instantly. Consumed with anger, Ellie gets her gun, aims, and shoots, but she missed Digger only to have the bullet ricochet and hit a propane tank which exploded next to Ms. Ellie, killing her instantly. Stricken with grief and loneliness, Jock looks up his old air corps nurse girlfriend. They reconcile, get married, and Jock finally acknowledges Ray as his son in a heartfelt letter of reconciliation. Exactly 2 years and 364 days into the marriage with the nurse, Jock dies of a heart attack after eating an entire 72 ounce steak in 1 hour at the Big Texan Steak Ranch in Amarillo.³⁰

Answers to Hypothetical #1

1969 to Present: Ray gets nothing because he has no qualifying proof paternity to Jock. Ellie's heirs are J.R., Bobby, and Gary per capita, giving them 1/3 of both SouthFork and the Ewing Estate each. The fact that Southfork is the ancestral property of Ellie is irrelevant.

1959 to 1969: Same as 1933 to 1959.

1933 to 1959: Ray gets nothing because his mother never married Jock nor was there a legally deficient attempted marriage between Nurse and Jock. Ellie's heirs are J.R., Bobby, and Gary per capita, giving them 1/3 of all of the property. The fact that Southfork is the ancestral property is not relevant because Ellie died with issue.

1848 to 1933: Ray gets nothing because his mother never married Jock nor was there a legally deficient attempted marriage between Nurse and Jock. Ellie's heirs are J.R., Bobby, and Gary per capita, giving them 1/3 of all of the property. The fact that Southfork is the ancestral property is not relevant because Ellie died with issue.

Answers to Hypothetical #2

1969 to Present: Ray gets nothing because he has no qualifying proof his paternity to Jock. Clayton Farlow gets all of Southfork and the Ewing Estate.

1959 to 1969: Same as 1933 to 1959.

1933 to 1959: Ray gets nothing because his mother never married Jock nor was there a legally deficient attempted marriage between Nurse and Jock. Southfork ascends from Ellie up to her nearest collateral heir on her father's side as ancestral property. In this case, her first cousin John Smith takes all of

³⁰ Those who dare undertake this spectacle of human gluttony can be viewed doing so online at <http://69.10.155.161:5080/maidining/>

SouthFork. The remainder of the Ewing estate also ascends to Ellie's line, leaving John Smith and Jackie Johnson each with 1/2 of the Ewing Estate.

1848 to 1933: Ray gets nothing because his mother never married Jock and there was no legally deficient marriage to Jock. Southfork ascends from Ellie up to her nearest collateral heir on her father's side as ancestral property. In this case, her first cousin John Smith takes all of SouthFork. John is a collateral heir from Ellie's father's line, so he takes all of the Ewing Estate as well.

Answers to Hypothetical #3

1969 to Present: Jock inherits Southfork from Ellie because they were married more than 3 years. If Ray follows the statutory procedure proving he is Jock's child, he gets Southfork and the Ewing Estate.

1959 to 1969: Same as 1933 to 1959. Were Ray not legitimated, however, he could take as Nurse's heir if she pre-deceased Jock.

1933 to 1969: Southfork ascends from Ellie up to her nearest collateral heir on her father's side as ancestral property. In this case, her first cousin John Smith takes all of SouthFork. Because Ray was legitimated by his mother and Jock's marriage, he gets the Ewing Estate to himself.

1848 to 1933: Southfork ascends from Ellie up to her nearest collateral heir on her father's side as ancestral property. In this case, her first cousin John Smith takes all of SouthFork. Because Ray was legitimated by his mother and Jock's marriage, he gets the Ewing Estate to himself.

II. Rights of Surviving Spouses

At common law, surviving spouses of the deceased received an interest in the estate of their deceased spouse.³¹ The term "dower" at common law refers to the right of the wife to a life estate in the land of her deceased husband, and the term "curtesy" at common law refers to the right of the husband to a life estate in all of the lands of his deceased wife, provided that children were born into the marriage.³² Today, statutes rather than common law govern the right of surviving spouses, but the common law terminology persists.³³ In Arkansas, most lawyers and judges refer to the surviving spouse's share as "dower" even though the surviving spouse may be male. This course will follow the convention of Arkansas practitioners by using the term "dower" to refer to the rights of surviving husbands and wives post 1981.

A. Identifying lands Subject to Dower or Curtesy

Regardless of whether the right is for the widow or the widower, when the surviving spouse was in a valid marriage with the deceased spouse and the deceased spouse had seisen in the land during the

³¹ MCGOVERN AND KURTZ, *infra* note 9 at 137.

³² *Id.*

³³ Arkansas struck down all surviving spouse statutes that had gender-biased relics from the common law in 1981.

marriage, then the surviving spouse has a dower or curtesy right.³⁴ The requirement of marriage presents few pitfalls. Rare exceptions exist. For example, the marriage could be void for want of capacity or legal defect.³⁵ Seisen, the other prerequisite for dower, is a legal term of art meaning that the owner had the right to possession of the land.³⁶ Because it is a somewhat nebulous legal concept, there are many reported cases that examine whether a spouse had seisen. Generally, seisen will not attach to any remainder or reversion interest that does not consummate during the lifetime of the spouse holding the remainder or reversion interest.³⁷ For example, if A holds a life estate with a remainder to B who is married to C, and B dies before A does, then B can never be seized of the land during his lifetime. Thus, C has no right in the land. The same reasoning applies to reversions.³⁸ Seisen will attach to an equitable estate, including contracts to purchase land in which the deceased spouse had paid consideration.³⁹

B. Amount of Dower/Curtesy

The amount of the surviving spouse's rights varies between males and females over the course of Arkansas's history. Also, whether or not the deceased had children varies the amount of dower or curtesy. The same definition and requirements of being a "child" under intestacy applies to the dower requirement.⁴⁰ Under current law (1981 to present), if the deceased spouse had children, the surviving spouse gets a one-third life estate in all lands in which the deceased spouse had seisen during the marriage.⁴¹ Should the deceased spouse die without children, differences between ancestral property and new acquisitions come into consideration. For new acquisitions, the surviving spouse gets one half of the lands in which the deceased spouse had seisen during the marriage in fee.⁴² The surviving spouse, however, receives only a life estate in half of the lands for ancestral property.⁴³

From 1939 to 1981, the law did not vary in substance from the current law with regard to surviving spouses of intestates. The only difference was semantics. As in common law, the former law labeled the share allotted the surviving husband as "curtesy" and the share allotted the wife as "dower." Prior to 1939, there were two schemes for the husband and one for the wife. From statehood to 1925, the husband could receive common law curtesy.⁴⁴ That is, a life estate in 100% of the wife's lands provided that any children were born to the marriage. In 1925, the legislature modified the common law to provide the husband with a 1/3 life estate in the lands if the wife died with children and a 1/2 life estate in the lands if the wife died without children.⁴⁵ This changed to comport with the wife's rights in

³⁴ ARK. CODE ANN. § 28-11-301(a). A third requirement to impute is that the surviving spouse did not murder the deceased spouse. *Id.* at § 28-11-204. This statutory provision has fact-specific exceptions set out in case law and should be researched prior to making a determination of whether the slaying spouse and her heirs may have an interest.

³⁵ See *E.g. Spears v. Spears*, 178 Ark. 720, 12 S.W.2d 875 (1928) (contest over whether subsequent marriage of deceases was bigamous); another example might include marriage to a person under the disability of infancy.

³⁶ BLACK'S, *supra* note 1 at 631.

³⁷ *Maloney v. McCullough*, 215 Ark. 570, 221 S.W.2d 770 (1949).

³⁸ *Davis v. Davis*, 219 Ark. 623, 243 S.W.2d 739 (1951).

³⁹ *Spalding v. Haley*, 101 Ark. 296, 142 S.W. 172 (1911).

⁴⁰ See *E.g. Sanders v. Taylor*, 193 Ark. 1095, 104 S.W.2d 797 (1937) (dower in fee under § 28-11-307 held inapplicable for man who died with surviving adopted children). See also Section I(B), *supra*. By implication, the term "child or children" in both §§ 28-11-307 and 28-11-301 should meet the same requirements as with intestate succession.

⁴¹ ARK. CODE ANN. § 28-11-301(a).

⁴² *Id.* at § 28-11-307 (a)(1)

⁴³ *Id.* at (b).

⁴⁴ See Act 149 or 1925.

⁴⁵ *Id.*

1939. Dower for the widow was a 1/3 life estate in the husband's lands from statehood to 1891 whereupon the widow began to receive dower in fee when her husband died without children.⁴⁶ From then, the provisions for the widow remained unchanged with the husband's rights becoming equal to the wife's, as previously mentioned, in 1939.⁴⁷

C. Extent and Nature of Dower Interest

The extent of dower is both far-reaching and durable.⁴⁸ A spouse's dower interest attaches to all seized lands conveyed by the deceased spouse during the marriage to the surviving spouse.⁴⁹ Furthermore, one spouse cannot unilaterally extinguish the other spouse's dower rights by conveying the land away without the other spouse's consent.⁵⁰ The non-consenting spouse may seek to recover lands conveyed by the deceased spouse.⁵¹ The statutes bar the ability of the non-consenting spouse to recover lands conveyed after the conveyance is of record for 7 years.⁵²

Until consummated and assigned, dower is inchoate.⁵³ The term "inchoate" means that something is partially done or imperfect.⁵⁴ For inchoate dower interests, an operator must impound 1/3 of the royalty for the surviving spouse and withhold royalty payments "until the rights of the surviving spouse are determined."⁵⁵ Dower is not alienable in the lifetime of the seized spouse, but the unseized spouse may relinquish dower rights during the lifetime of the seized spouse.⁵⁶ To consummate dower, the only requirement is the death of the seized spouse.⁵⁷ Upon the death of the seized spouse, dower is consummated, but unassigned.⁵⁸ A spouse with a consummated, but unassigned dower interest conveys no right to possession to a grantee.⁵⁹ Such a grantee, however, does receive the spouse's equitable right to compel the heirs to assign the dower.⁶⁰ The heirs of the intestate are under a duty to assign the surviving spouse dower.⁶¹ Once assigned, the dower is perfected and carries the right to possession.⁶²

⁴⁶ See English's Digest 59 and Act of March 24, 1891.

⁴⁷ The Arkansas Supreme Court recognized the equal treatment of surviving spouses of an intestate under the law from 1939 to 1981 in *Beck v. Merritt*, 280 Ark 331, 657 S.W.2d 549 (1983).

⁴⁸ Herein, the author will refer to the surviving spouse's share generically as "dower." The extent and nature of dower and curtesy are the same.

⁴⁹ *Id.* at § 28-11-301.

⁵⁰ *Id.* at § 28-11-201(a).

⁵¹ See *Id.* and See also *E.g. Roetzel v. Beal*, 196 Ark. 5, 116 S.W.2d 591 (1938) (widow recovered her dower interest from one purchasing the husband's interest at an execution sale). The exception to this is dower in fee, wherein the surviving spouse's right is immediately vested, making the surviving spouse a tenant in common with the heirs of the deceased. See note 37, *infra*.

⁵² See ARK. CODE ANN. § 28-11-203.

⁵³ See AM. JUR. 2D Dower and Curtesy §§ 32 and 34.

⁵⁴ BLACK'S, *infra* note 1 at 337.

⁵⁵ ARK. CODE ANN. at § 28-11-304. This section seeks to protect the surviving spouse until the assignment of dower, and presumably, the Legislature's intent is to encourage the heirs to assign the surviving spouse dower by directing the operator to pay nothing to the heirs or spouse until the heirs make the assignment.

⁵⁶ *Le Croy v. Cook*, 211 Ark. 966, 204 S.W.2d 173 (1947).

⁵⁷ AM. JUR. 2D Dower and Curtesy § 34.

⁵⁸ See AM. JUR. 2D Dower and Curtesy §§ 32 and 34.

⁵⁹ See *Barnett v. Meacham*, 62 Ark. 313, 35 S.W. 533 (1896); *Brinkley v. Taylor*, 111 Ark. 305, 163 S.W. 521 (1914).

⁶⁰ *Weaver v. Rush*, 62 Ark. 51, 34 S.W. 256 (1896); *Baum v. Ingraham*, 141 Ark. 243, 216 S.W. 704 (1919).

⁶¹ ARK. CODE ANN. § 28-39-301(a).

⁶² AM. JUR. 2D Dower and Curtesy § 32.

Prior to assigning the dower, the heirs must execute a written agreement giving the surviving spouse the right to execute oil and gas leases and to receive all payments on any lease during the surviving spouse's lifetime.⁶³ The assignment is a written instrument that describes the lands assigned with the endorsed acceptance of the spouse and an acknowledgment from both spouse and heirs.⁶⁴ The assignment should be recorded with the probate clerk.⁶⁵ The exception to assignment as a requirement of perfection of dower interests is dower in fee when there are no children and the property is a new acquisition.⁶⁶ If the heirs fail to make the assignment, the surviving spouse may petition the court to compel the heirs to assign dower.⁶⁷ If the court cannot partition the land without great prejudice to either party, then the court will either order the sale or rental of the land.⁶⁸ An action to compel assignment generally abates upon the surviving spouse's death.⁶⁹ When the surviving spouse dies, the remainder to the dower interest passes by the deceased spouse's will or by intestacy, whichever is applicable.⁷⁰

Dower in fee comes off the top of the intestate's estate.⁷¹ Whatever is left after the dower share is the "heritable estate."⁷² Life estate dower is superior to the rights of the intestate's heirs, but does not actually reduce the heritable estate.⁷³ This distinction is important in the current inheritance code which provides that a surviving spouse of less than 3 years takes only one half of the "heritable estate."⁷⁴

D. Hypotheticals

Take the facts and Hypotheticals 1-3 from Section I(D) and determine the dower rights of each surviving spouse under the current dower law. Also, determine the dower rights and intestate share of the surviving spouse and the heirs in Hypothetical #2 under the current Table of Descent assuming Clayton was married to Ellie for only 2 years and 364 days at her death.

Answer to Hypothetical #1: Trick question. Ellie and Jock held the Ewing Estate as tenants by the entirety, so she had no need for dower in the Ewing Estate during the year she was widowed.

Answer to Hypothetical #2: Another trick question. Ellie has no descendants. Clayton owns everything.

⁶³ ARK. CODE ANN. § 28-39-302.

⁶⁴ *Id.* at § 28-39-301(b).

⁶⁵ *Id.* at (c).

⁶⁶ *Barton v. Wilson*, 116 Ark. 400, 172 S.W. 1032 (1916).

⁶⁷ ARK. CODE ANN. § 28-39-303.

⁶⁸ *Id.* at § 28-39-305 and 306.

⁶⁹ *Burrus v. Butt*, 126 Ark. 584, 191 S.W. 33 (1917). (administrator of widow's estate could not sue to recoup rents from widow's unassigned dower interest). The author was unable to find an Arkansas case stating whether a grantee of a surviving spouse's consummate, but unassigned dower interest. The reasoning of *Burrus*, however, seems applicable and appropriate because the action could only be brought by the surviving spouse during the his or her lifetime, so it stands to reason a grantee of the surviving spouse should be put in no better position.

⁷⁰ ARK. CODE ANN. § 28-11-301.

⁷¹ *Id.* at § 28-9-206(b)(1).

⁷² *Id.* at (c).

⁷³ The author believes that the correct reading of § 28-9-206 is the "subject to" language means that life estate dower is superior to the heir's interest, and that the dower in fee provisions of § 28-11-307 reduce the intestate's heritable estate.

⁷⁴ *Id.* at § 28-9-214.

Answer to Hypothetical #3: Nurse gets 1/3 of both SouthFork and the Ewing Estate for life (assuming a court would—and it should—recognize Ray as Jock’s child).

Answer to Modified Hypothetical #2: A tricky, but not trick question. Remember that dower in fee comes off the top of the estate, and that a surviving spouse gets ½ of the “heritable” estate under the Tables of Descent. Clayton gets dower in fee of ½ of the Ewing Estate. The “heritable” estate is now ½ in fee. Clayton’s intestate share of Ewing Estate, then, is ½ of ½ or ¼. The remaining 1/4 of the Ewing Estate goes in equal shares to Ellie’s cousins. As for SouthFork, it is ancestral property, and Clayton gets a life estate in half as dower. Because his life estate does not actually reduce the “heritable” estate, Clayton gets a full half of SouthFork under the Tables of Descent. Ellie’s cousins hold the remainder to Clayton’s endowed life estate.⁷⁵

III. Possible Curative Measures

A. Ancillary Probate

The Arkansas Code imposes a 5 year time limit on the probate of wills of residents, but for nonresidents with estates probated in another state that met the time requirements of that state, there is no time limit for ancillary administration in Arkansas.⁷⁶ Until someone probates the will of a non-resident in Arkansas, the rights of the intestate heirs, not the will beneficiaries, are superior as to Arkansas property.⁷⁷ The language of the statute establishing this priority reads as follows:

[T]he rights and interests in the real property which, after the death of the testator if it is assumed that he or she died intestate, have been acquired by purchase, as evidenced by one (1) or more appropriate instruments which have been properly recorded in the office of the recorder of the county in the which the real property situated and which would be valid and effective had the decedent died intestate, shall not be adversely affected by the probate of the will in this state after the expiration of the time limit imposed by subsection (a) of this section.⁷⁸

The subsection (a) referenced in the statute is the 5 year limit imposed on the probate of wills of residents of Arkansas.⁷⁹

The only case interpreting this statute is *Cooper v. Tosco Corporation*, 272 Ark. 294, 613 S.W.2d 831 (1981). In *Cooper*, the appellants, Cooper and Adams, were the beneficiaries of Rowland’s will.⁸⁰ Rowland died testate in 1966 in Louisiana, and his will was probated in 1968 in Louisiana.⁸¹ Under his will, Rowland did not leave his Arkansas real estate to his only child, Edith.⁸² Instead,

⁷⁵ Arkansas abolished the ancestral/new acquisition distinction for purposes of intestacy only, not for dower. ARK. CODE ANN. § 28 28-9-219.

⁷⁶ See *Id.* at § 28-40-103 and Section I(B), *infra*.

⁷⁷ *Id.*

⁷⁸ *Id.* at § (c)(2).

⁷⁹ *Id.* at § (a).

⁸⁰ *Cooper*, 272 Ark. at 295, 613 S.W.2d at 831.

⁸¹ *Id.*

⁸² *Id.*

Cooper and Adams were his devisees as to the Arkansas real estate.⁸³ In 1979 only weeks before Rowland's will was offered for probate in Arkansas and more than 5 years after Rowland's death, Edith conveyed the minerals to the Arkansas property to her aunt Fahy.⁸⁴ Cooper and Adams contended that the above quoted statute implies that the purchaser must be a good faith purchaser without notice.⁸⁵ The court refused to impute "good faith purchaser without notice" into the statute and found that the deed to aunt Fayh cut off the rights of the will devisees.⁸⁶ In other words, it is a pure race to the courthouse.

Undoubtedly, aunt Fahy knew Edith had no right to the Arkansas property. Fayh's full name was Fayh Rowland,⁸⁷ and she was probably the decedent's sister or sister-in-law. The statute and the case worked a rather unjust result, but both statute and case leave room for a future court to soften the law under the right set of facts. For one, the *Cooper* court notes that neither Rowland nor Cooper alleged fraud.⁸⁸ Also, the language of the statute indicates that it should apply "if it is assumed that he or she (the decedent) died intestate." Perhaps "assumed" is synonymous with "presume." A common "curative" technique seen in Arkansas is simply to file the nonresident's will or foreign probate of record in the real estate records of the County of the situs of the property. It is possible that this would serve to defeat the "assumption" that the decedent died intestate. This is entirely speculative, and it would not serve clients very well to gamble on the court softening its interpretation of the statute in the future. The only certain cure to a problem such as in *Cooper* is an ancillary probate.

Petitioning for ancillary probate is a relatively simple process.⁸⁹ The petition should include an authenticated copy of the will and order admitting the will to probate in the foreign jurisdiction.⁹⁰ If administration in the foreign jurisdiction is closed, the petition should also include a certified copy of the final order distributing the estate.⁹¹ The will should be executed with two witnesses or be entirely in the handwriting of and executed by the testator.⁹² If not, the petition should state the time and place of execution and the testator's domicile at the time of execution and of death.⁹³ The attorney should file the ancillary petition in the county of the greatest value of the testator's property.⁹⁴ If the probate needs administration, then the petition to probate the will should also include a petition to appoint a personal representative.⁹⁵ A personal representative must furnish a fiduciary bond, or seek waiver from the court.⁹⁶

⁸³ *Id.*

⁸⁴ *Id.*

⁸⁵ *Id.* at 296, 831.

⁸⁶ *See Cooper* 272 Ark. at 296-97, 613 S.W.2d at 832-33.

⁸⁷ *Id.* at 295, 831.

⁸⁸ *Id.* at 296, 831.

⁸⁹ *See* ARK. CODE ANN. § 20-40-107 for the general requirements of the petition.

⁹⁰ *Id.* at § 28-40-120.

⁹¹ This is not required by the statute, but it should be done where the estate is closed in the foreign jurisdiction so that the Arkansas court and those searching real estate records have notice of the foreign court's final judgment. This both hastens the process and provides certainty.

⁹² *Id.* at §§ 28-40-120(c), 28-25-103, and 28-25-104

⁹³ *Id.* at § 28-40-120(c).

⁹⁴ *Id.* at §§ 28-40-120(d)(1) and 28-40-102.

⁹⁵ The statutes do not require the appointment of a personal representative with the filing of the petition for probate. *See* ARK. CODE ANN. § 28-40-107. For an estate closed in another jurisdiction with no personal property to devise, there is no need for the appointment of a personal representative unless a creditor comes forward who requires payment from the estate. In that instance, the proponent can file a separate petition for to appoint a personal representative. The personal representative can then do whatever is necessary with the estate property to satisfy the estate's debts. For a probate currently under

Lastly, the statutes require notice of the ancillary probate.⁹⁷ This is the most time-consuming aspect of probate. The statutes entitle all creditors and those with claims against the deceased to notice of the probate.⁹⁸ The administrator or proponent of the will (in the case of an estate without administration) must publish notice of the probate once a week for two consecutive weeks in the newspaper of general circulation in the county of the probate.⁹⁹ The notice must state the date of the administrator's appointment, or if there is no administration, then the address of the will's proponent and attorney.¹⁰⁰ The notice should substantially comply with the statutory form, include a statement to the effect that all claims against the decedent and the estate be made in the time permitted by law, and a statement that contest of the will must be filed in time permitted by law.¹⁰¹ In addition to the publication, the statutes require that all persons whose names appear in the petition be served by regular mail.¹⁰² One month following notice by publication, a notice to all outstanding creditors (if applicable) should be served by registered mail or process server.¹⁰³

For an estate long-closed in the foreign jurisdiction, the ancillary probate is simply a petition for probate without petitioning for an administrator and a long wait for all notices to expire. Once the applicable notice periods expire without claim or contest, the statutes bar all claims against the estate.¹⁰⁴ In the interim, a lessee or purchaser from a will's beneficiary should file a certified copy of the will and order admitting the will to probate in all counties where he or she purchased or leased property from the decedent in order to obtain the protection of the recording statutes. At the close of the estate, a certified copy of the final order should also be filed of record in each county where the decedent had real property. An example of a petition for ancillary probate with a personal representative is included as Exhibit E. An example of an ancillary probate for an estate without administration is included as Exhibit F.

B. The Affidavit of Death and Heirship

An affidavit of death and heirship is a legitimate means of evincing title to the interests of an intestate. The affidavit, however, should contain all necessary information to apply the Arkansas Table of Descents and ascertain the rights of the surviving spouse. The affidavit "should be made by a person competent to testify in court" and "state facts rather than conclusions."¹⁰⁵ At a minimum, the substance of the affidavit of death and heirship to cure the interests of an intestate should affirmatively state:¹⁰⁶

administration in a foreign jurisdiction, the foreign personal representative can petition to be the personal representative for the ancillary proceeding, but the court will likely require a separate bond. See *Id.* at § 28-42-101 *et. seq.*

⁹⁶ *Id.* at § 28-48-201.

⁹⁷ *Id.* at §§ 28-40-120(d)(2) and 28-40-111.

⁹⁸ *Id.* at § 28-40-111(a)(1)(A).

⁹⁹ *Id.* at §§ 28-40-111(d)(1) and 28-1-112(b)(4)(A).

¹⁰⁰ *Id.* at § 28-40-111(a)(1)(A) and (b).

¹⁰¹ ARK. CODE ANN. 28-40-111(c)(1-4), (a)(1)(A), and (a)(3).

¹⁰² *Id.* at § 28-112(b)(4)(B). A waiver of this requirement is common, and it is best practice to obtain written waivers from the will beneficiaries prior to filing the petition to file them with the petition.

¹⁰³ *Id.* at §§ 28-40-111(a)(4)(A) and 28-1-112(b)(1-3).

¹⁰⁴ *Id.* at § 28-40-111(a)(1)(A). This represents the point at which title is clear if there were no claims against the estate and there was no contest of the probate.

¹⁰⁵ ARKANSAS BAR ASSOCIATION, STANDARD FOR EXAMINATION OF REAL ESTATE TITLES IN ARKANSAS 26 (2000).

¹⁰⁶ *Id.*

1. That the decedent died intestate;
2. When and where the decedent died;
3. The relationship, if any, of the affiant to the decedent and the source of knowledge concerning the decedent;
4. The marital status of the decedent at the time of death, name of surviving spouse, and the duration of the marriage up to the time of the intestate's death;
5. If the spouse predeceased the intestate, then the time and place of the spouse's death;
6. Whether the intestate had children;
7. The names of all natural or adopted children of the intestate;
8. If there are no children or a surviving spouse of more than 3 years, then all other all other information necessary to determine the decedent's heirs-at-law in accordance with the applicable Arkansas Tables of Descent;
9. The same information set out in items 1-8 regarding any deceased child, grandchild, or other applicable descendent.

The affidavit should be sworn and acknowledged by a notary.¹⁰⁷ Details are important in drafting an affidavit of death and heirship. The drafter should obtain all possibly relevant information about the intestate and review it carefully prior to drafting the affidavit. A sample affidavit for the current intestacy scheme (1969 to present) based on the facts and hypothetical #2 in Section I(D) is attached as Exhibit G. Note that the information included in this sample affidavit differs from what one might include for an affidavit for either of the other intestate schemes.

Affidavits are merely evidentiary in Arkansas.¹⁰⁸ To conclusively "prove" heirship for an intestate, a person claiming an interest to the property can file an action for Determination of Heirship.¹⁰⁹

C. The Affidavit for Collection of Small Estates

The Affidavit of Collection of Small Estates is a very streamlined, inexpensive process for estates with a value, excluding homestead of and statutory allowances for spouse and minor children, of \$100,000.¹¹⁰ The estate must not have a personal representative or have an application pending for the appointment of a personal representative, and 45 days must have elapsed since the decedent's death.¹¹¹ If the estate meets all prerequisites, any distributee of the estate may file an affidavit with the probate clerk of the circuit court setting forth:

1. That there are no unpaid claims or demands against the decedent or his or her estate, that the Department of Human Services furnished no federal or state benefits to the decedent, or, that if such benefits have been furnished, the department has been reimbursed in accordance with state and federal laws and regulations;

¹⁰⁷ *Id.*

¹⁰⁸ ARKANSAS BAR ASSOCIATION at 25, *infra* note 55.

¹⁰⁹ ARK. CODE ANN. § 28-83-101. This action is a species of declaratory judgment, but it allows any interested person to file the action without having to alleging the how the petitioner's interest might be harmed.

¹¹⁰ *Id.* at § 28-41-101(a)(3). The cost to file the affidavit is only \$25. *Id.* at § 28-41-101(b)(1).

¹¹¹ *Id.* at (a)(1-2).

2. An itemized description and valuation of the personal property and a legal description and valuation of any real property of the decedent, including the homestead;
3. The names and addresses of persons having possession of the personal property and the names and addresses of any persons possessing or residing on any real property of the decedent; and
4. The names, addresses, and relationship to the decedent of the persons entitled to and who will receive the property.¹¹²

The distributee should also attach a copy of the decedent's will.¹¹³ The distributee files the affidavit with the clerk, and the clerk provides a certified copy of the affidavit to "any person owing any money, having custody of any property, or acting as registrar or transfer agent of any evidence of interest, indebtedness, property, or right" of the estate.¹¹⁴ To distribute real property, the statute gives the distributee the option to publish notice to creditors of the estate containing the following information:

1. The name of the decedent and his or her last known address;
2. The date of death;
3. A statement that the affidavit was filed, the date of the filing, and a legal description of all real property listed in the affidavit;
4. A statement requiring all persons having claims against the estate to exhibit them, properly verified, within three (3) months from the date of the first publication of the notice, or they shall be forever barred and precluded from any benefit in the estate;
5. The name and mailing address of the distributee or his or her attorney; and
6. The date the notice was first published.¹¹⁵

The distributee should publish notice of the collection once a week for two consecutive weeks in the newspaper of general circulation in the county of the probate.¹¹⁶ In addition to publication, the statutes require that all persons whose names appear in the petition be served by regular mail.¹¹⁷ Once the notice period is complete, the distributee may issue him or herself an administrator's deed.¹¹⁸

¹¹² See *Id.* at (a)(4)(A-D)

¹¹³ Though not explicitly required, it is an implied requirement if the affidavit seeks to prove devise by will rather than intestacy. Also, the statute provides that there be no additional charge for attaching the will. *Id.* at (b)(1).

¹¹⁴ *Id.* at (a)(5).

¹¹⁵ *Id.* at (b)(2)(A-B).

¹¹⁶ See ARK. CODE ANN. §§ 28-40-111(d)(1) and 28-1-112(b)(4)(A).

¹¹⁷ *Id.* at § 28-1-112(b)(4)(B).

¹¹⁸ *Id.* at § 28-42-102(d).

The real estate bar holds the Affidavit for Collection of Small Estates in great suspicion.¹¹⁹ The real estate bar's concerns are valid. The courts, however, finally had the opportunity to review the Small Estates statute in *Osborn v. Bryant*.¹²⁰ In that case, the decedent, Lacy Bryant, died testate with a widow and eight children as a resident of Jackson County, Arkansas.¹²¹ Lacy's will left his real property to his wife for life, and following that, the will gave the option to purchase the property for \$200 per acre to Osborn with the proceeds to go to Lacy's children.¹²² If Osborn failed to exercise the option, the property went straight to Lacy's children.¹²³ Osborn filed the affidavit along with Lacy's will.¹²⁴ The will was in all respects valid, and had proof of execution.¹²⁵ Osborn also followed the notice procedure in the statute.¹²⁶ Following the notice period, Osborn executed an administrator's deed to herself.¹²⁷ Lacy's widow lived on the property for 9 years following the deed.¹²⁸ After the widow's death, Lacy's children filed a declaratory judgment action against Osborn to nullify the administrator's deed and to declare that Lacy died intestate.¹²⁹

Lacy's children argued that the Small Estates procedure was a "probate proceeding" under ACA § 28-40-104 and that the will attached to the affidavit could therefore not be used as evidence of devise.¹³⁰ The Court of Appeals held that the plain language of the statute exempts the Small Estates procedure from § 28-40-104.¹³¹

This case is from the Arkansas Court of Appeals, not Arkansas Supreme Court, so the precedential value of the case is limited. Aside from the explicit holding that § 28-4-104 does not apply to the Small Estates procedure, the important implied holding of the case is that where the distributee follows the statutory notice procedures, the administrator's deed is good to transfer title.¹³² The case, however, leaves a number of important issues unresolved. First, the court in *Osborn* held that any will could be valid to prove title with the Small Estates procedure, but it is unknown if the Arkansas Supreme Court would agree that all wills, either in perfect compliance with the wills statutes or non-compliant, are entirely exempt from the requirements of 28-40-104(b)(2)¹³³ under the Small Estates Procedure. Secondly, the opponents of the affidavit in the *Osborn* case did not argue that the adequacy of the notice employed by the distributee.¹³⁴ Generally, courts reviewing statutory procedures require strict compliance with the statute, and any substantial and sometimes minute defect will result in failure

¹¹⁹ ARKANSAS BAR ASSOCIATION, *infra* note 55 at 29. "Despite their statutory recognition in Ark. Code Ann. § 28-41-101 *et. seq.*, Affidavits for Collection of Small Estates do not, in and of themselves, pass title to real estate, and should be given no greater weight or credibility than any other affidavit."

¹²⁰ No. CA 08-589, 2009 WL 215480 (Ark. App. Jan. 14, 2009).

¹²¹ *Id.* at *1.

¹²² *Id.*

¹²³ *Id.*

¹²⁴ *Id.*

¹²⁵ *Id.*

¹²⁶ *Osborn*, 2009 WL 215480 at *1.

¹²⁷ *Id.*

¹²⁸ *Id.*

¹²⁹ *Id.*

¹³⁰ *Id.* at *2.

¹³¹ *Id.* at *3.

¹³² *See Osborn*, 2009 WL 215480.

¹³³ "Except as provided in § 28-41-101, to be effective to prove the transfer of any property..., a will must be declared valid by an order of probate by the circuit court, except a duly executed and unrevoked will which has not been probated may be admitted as evidence of devise."

¹³⁴ *See Osborn*, 2009 WL 215480.

of the statutory procedure.¹³⁵ We do not know what, if any, defects in the notice procedure will cause the courts to render the Affidavit invalid. Finally, with an out-of-state decedent, it is somewhat uncertain whether it is possible to use the procedure to avoid the application of *Cooper*.¹³⁶ To obtain the protection against conveyances by rogue heirs, *Cooper* makes it clear that the statute requires a “probate” of a non-resident’s will.¹³⁷ The legislature provides that the will of a non-resident may be admitted to probate in this jurisdiction if probated in the decedent’s home jurisdiction in a timely manner.¹³⁸ The question remains whether the Small Estates procedure is a “probate.” If not, then only an ancillary probate can extend protection against conveyances of rogue heirs. If, however, the Court of Appeals is correct in its interpretation of § 28-40-104, then the only means to harmonize the exemption of the Small Estates procedure in §§ 28-40-104(b)(2) and 28-40-104(a)¹³⁹ is to classify a will attached to the Affidavit as a “will admitted to probate.” This would extend protection to the devisees of the will.

Without a binding precedent from the Arkansas Supreme Court on the issues of compliance with the wills statute, effectiveness of notice, and the effectiveness on the wills of out of state decedents, the Small Estates procedure presents appreciable risk of litigation. Those wishing to use the procedure to cure mineral titles should carefully consider the risk of litigation versus the cost savings of using the procedure.

¹³⁵ See *E.g. First Arkansas Bail Bonds, Inc. v. State*, 373 Ark. 470, 3009 WL 2132288 (2008) (strict compliance applied to statute dealing with notice of forfeiture of bail bond); *Hervey v. the Farms, Inc.*, 252 Ark. 881, 481 S.W.2d 348 (1972) (strict compliance applied to notice of garnishment statute); *Eddins v. Style Optics, Inc.*, 71 Ark. App. 102, 35 S.W.2d 315 (2000) (strict compliance to procedural requirement of probate statute applied); *Books-A-Million, Inc. v. Arkansas Painting and Specialties Co.*, 340 Ark. 467, 10 S.W.3d 857 (2000) (strict compliance applied to notice of mechanic lien statute); *Swartz v. Drinker*, 192 Ark. 198, 90 S.W.2d 483 (1936) (strict compliance applied to statute governing notice to out of state defendant for quiet title suit).

¹³⁶ See Section III(A), *infra*.

¹³⁷ See *Id.*

¹³⁸ *Id.*

¹³⁹ “No will shall be effectual for the purpose of proving title to or the right to the possession of any real or personal property disposed of by the will until it has been admitted to probate.” (emphasis added). The same statute also provides that “[t]he provisions of subsections (b) and (c) [sic] of this section shall be supplemental to existing laws relating to the time limit for probate of wills, and the effect of unprobated wills, and shall not be construed to repeal §28-40-103 and subsection (a) of this section or any other law not in direct conflict herewith.” *Id.* at § c. The statute is ambiguous in that it places the exemption for Small Estates in section b, but states that nothing in section b may be construed to repeal section a. This is antithetical, and the Small Estate exemption should appear in section a to support the Court of Appeal’s reading of the statute. The Court of Appeals does not note this, choosing to read sections a, b, and c independently. Curiously, there appears to be an error in section c where it refers to itself—the construction provision—as not changing itself. Perhaps there is a more substantial error or omission in the statute not identified by the Code Revision Commission.

Exhibit A: Table of Descent 1969 to Present

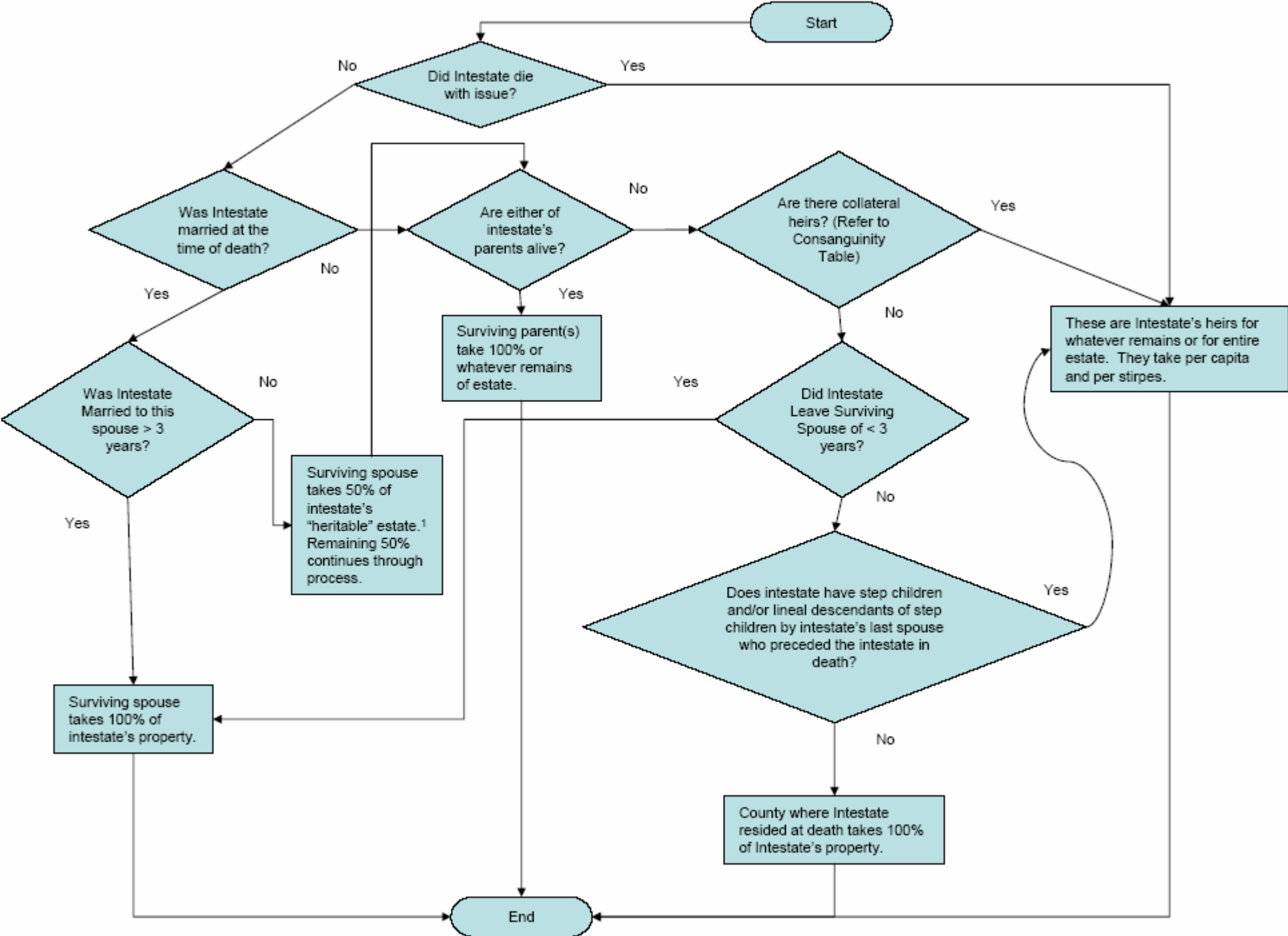

¹Note the term "heritable." Dower in fee can reduce the heritable estate.

Exhibit B: Table of Descent 1959-1969

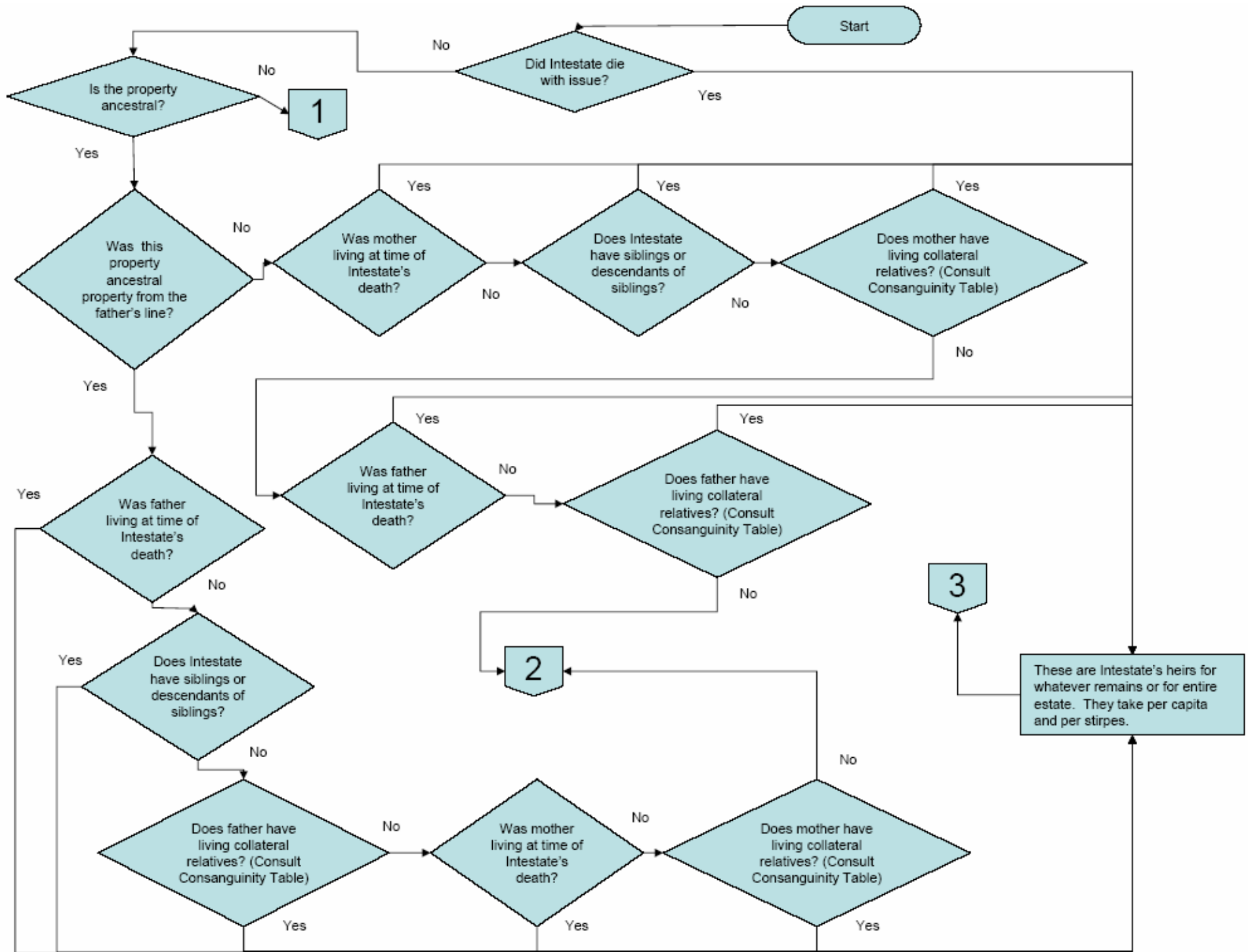
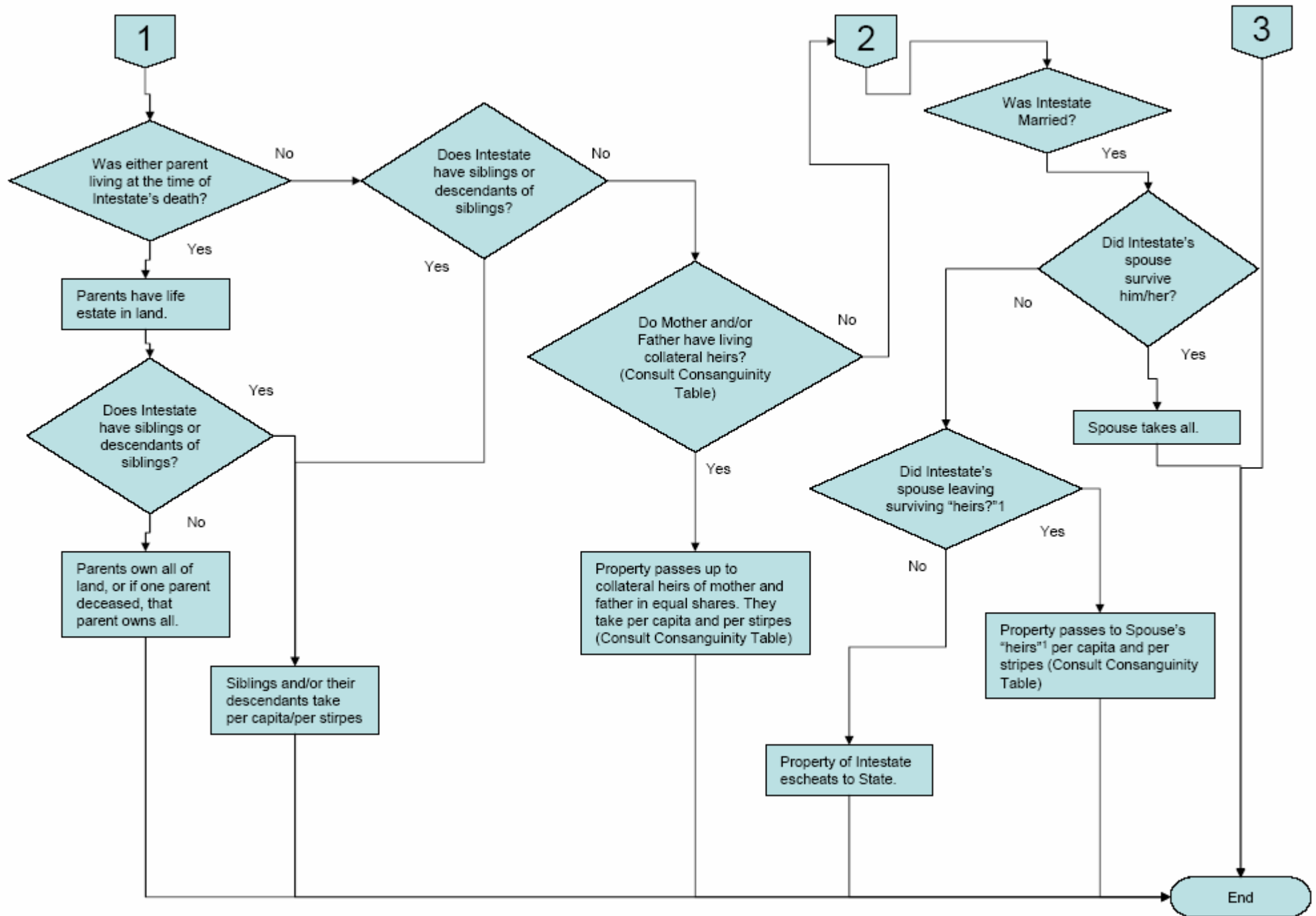

Exhibit B: Table of Descent 1959-1969 (cont)



1-The language of the statute in effect is "heir." Presumably, this would include any heir of the spouse and not just descendants.

Exhibit C: Table of Descent 1933-1959

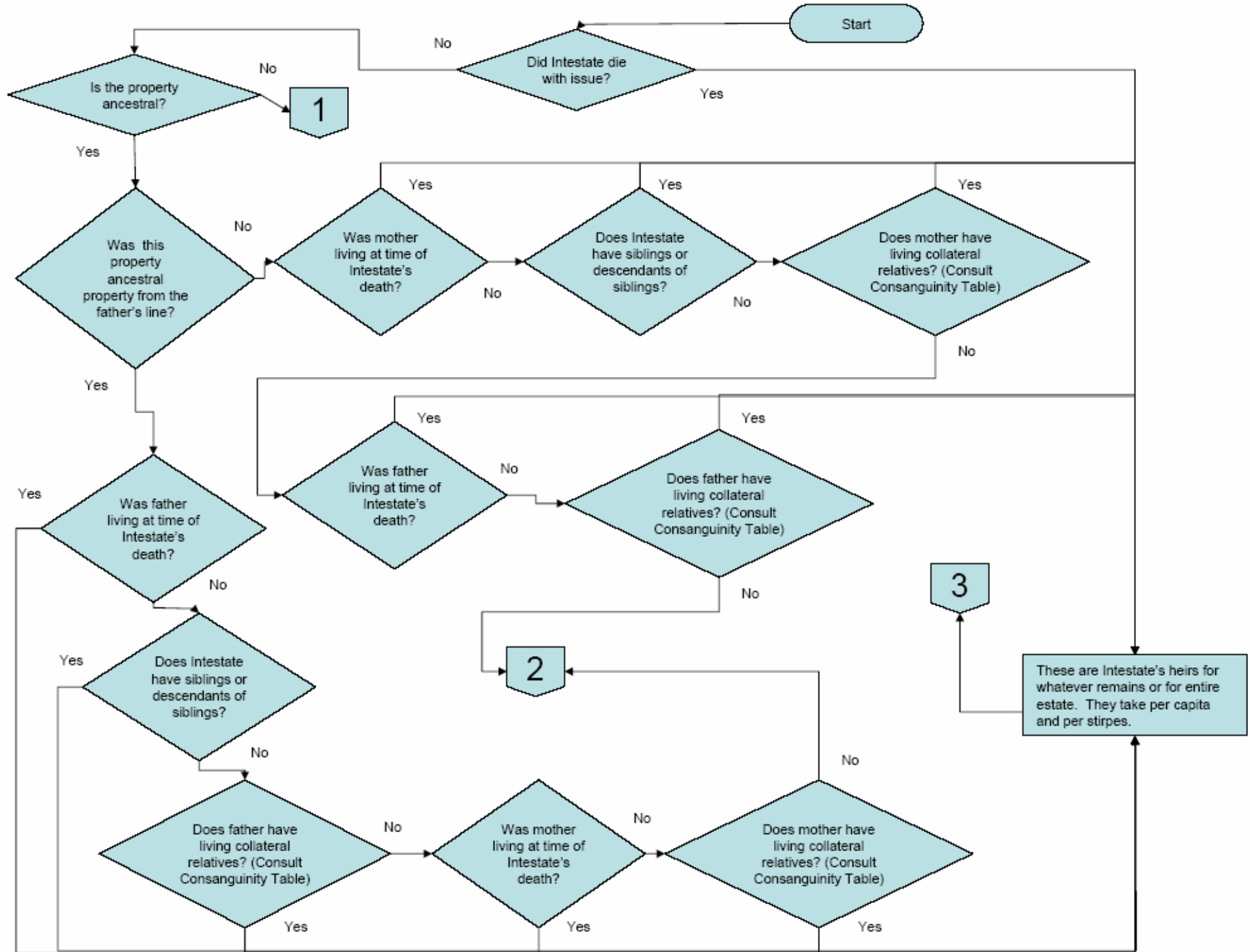

Exhibit C: Table of Descent 1933-1959 (cont)

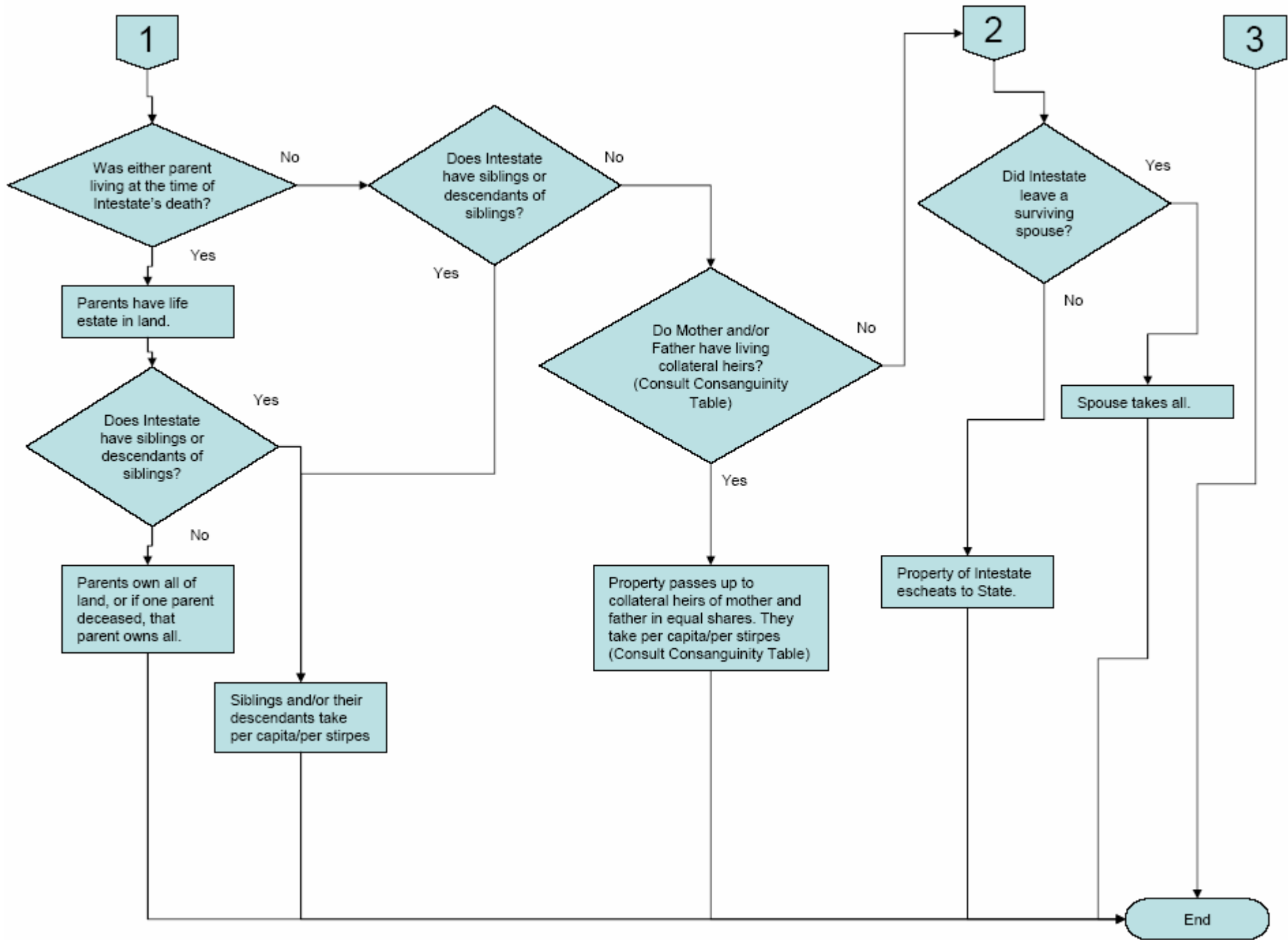
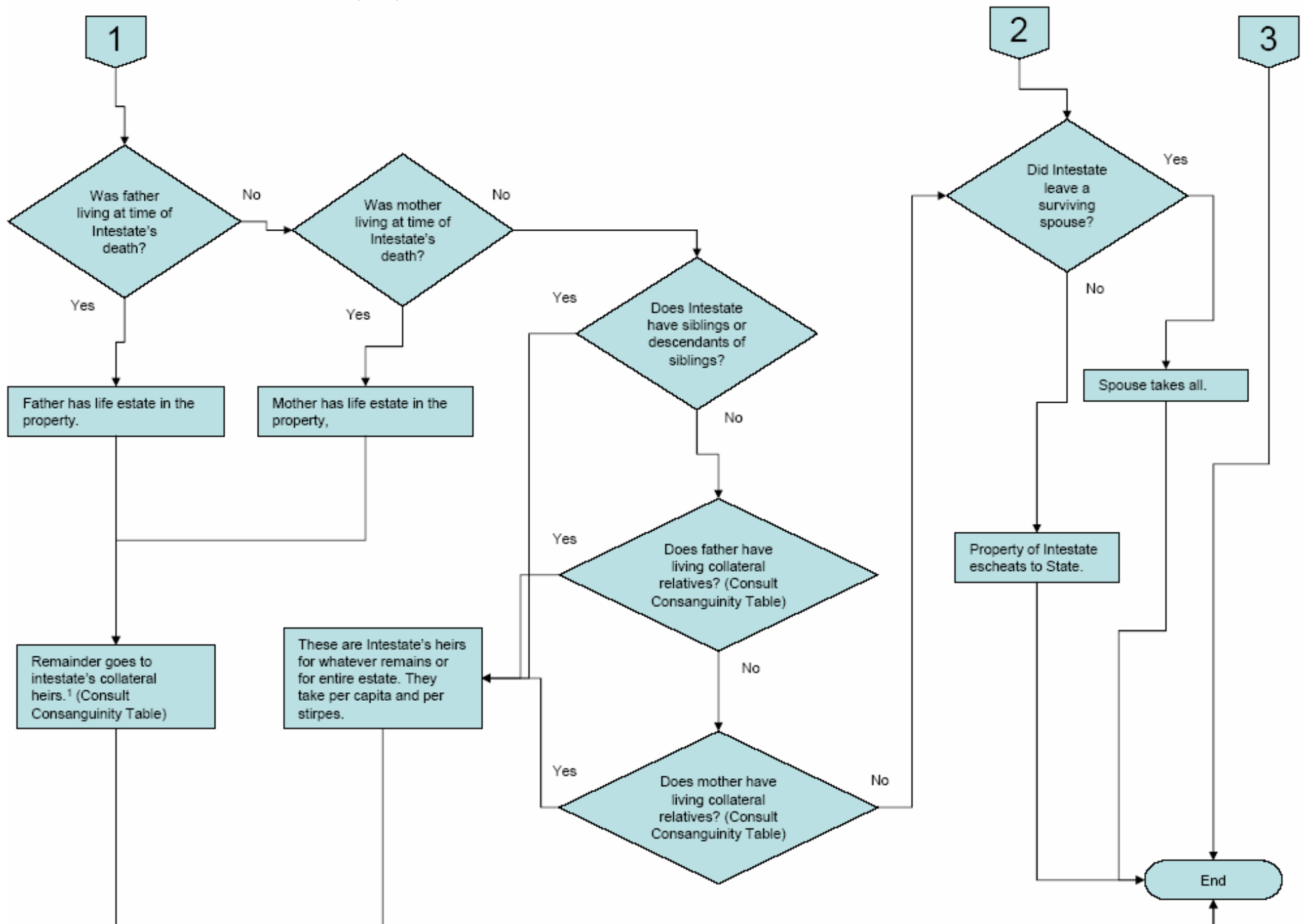

Exhibit D: Table of Descent 1848-1933 (cont)



¹This is the language of the statute in force. Presumably, the property would skip the Intestate's parents in favor of the Intestate's siblings due to the legislature's providing for a life estate to the parents.

Exhibit E: Petition for Ancillary Probate with Administration

IN THE CIRCUIT COURT OF WHITE COUNTY, ARKANSAS

**IN THE MATTER OF THE ESTATE
OF JOHN ROSS “JOCK” EWING,
DECEASED**

No. 2009C-001

**PETITION FOR ANCILLARY PROBATE OF WILL AND APPOINTMENT OF
PERSONAL REPRESENTATIVE**

Ellie Ewing, whose address is P.O. Box 123, South Fork, Texas, 73020, and whose interest in the estate of the above-decedent is that of devisee and surviving spouse, prays by and through her undersigned counsel, that a certain written instrument be admitted to probate as the Last Will of the decedent, and to appoint petitioner as personal representative. The facts, so far as they are known to or can reasonably be ascertained by petitioner, are:

- a. Decedent: The decedent, John Ross “Jock” Ewing, aged 79 years, who resided at the South Fork Ranch, South Fork, Texas, died at Cook Forth Worth Hospital, on March 25, 1985. Decedent owned certain real property located in White County, Arkansas.
- b. Proffered Will: The decedent left as his Last Will an instrument dated October 5, 1979, executed in Texas in accordance with Texas law. Due proof of the execution thereof in the manner required by law is made by notarized attestation clause in the decedent’s Last Will.

- c. Surviving Spouse, Heirs, and Devisees: The surviving spouse, heirs, and devisees of the decedent, and their respective ages, relationships to the decedent, and residence addresses are as follows:

Name	Age	Relationship	Address
Ellie Ewing	Adult	Surviving Spouse	South Fork Ranch, South Fork Texas
J.R. Ewing	Adult	Son	South Fork Ranch, South Fork Texas
Bobby Ewing	Adult	Son	South Fork Ranch, South Fork Texas
Gary Ewing	Adult	Son	South Fork Ranch, South Fork Texas

- d. Value of Estate: The probable value of the estate of the decedent is as follows:
- i. Real Property: Undetermined
 - ii. Personal Property: Undetermined
- e. Bond and Person to be Appointed: Your petitioner has been nominated in the decedent's Last Will to serve as Executrix, without bond, to administer the estate. All distributees are competent, have filed herein their written waivers of bond, their consent to appointment of Ellie Ewing as personal representative, there are no known unsecured claims against the estate, and the requirement for a fiduciary bond should be excused.

WHEREFORE, petitioner prays this Court enter an Order determining the fact of the death of the decedent, that the proffered instrument was executed in all respects according to law when the testator was competent to do so and acting without undue

influence, fraud, or restraint, has not been revoked, and is the decedent's Last Will, and appointing the foregoing nominee to administer the estate of the Decedent.

Respectfully submitted,

Attorney

By: _____
Attorney, Bar No. 1234567
Attorney for Petitioner

VERIFICATION

I, Ellie Ewing, Petitioner in the hereinabove entitled matter, do hereby swear, affirm and verify that I have read the entire Petition set forth above and I do hereby swear, affirm and verify that the allegations contained therein are true and correct to the best of my knowledge and belief.

Ellie Ewing

STATE OF TEXAS

COUNTY OF TARRANT

Subscribed and sworn to before me this ____ day of _____, 200_.

Notary Public

My Commission Expires: _____

-seal-

Exhibit F: Petition for Ancillary Probate without Administration

IN THE CIRCUIT COURT OF WHITE COUNTY, ARKANSAS

**IN THE MATTER OF THE ESTATE
OF JOHN ROSS “JOCK” EWING,
DECEASED**

No. 2009C-001

**PETITION FOR ANCILLARY PROBATE OF WILL WITHOUT
ADMINISTRATION**

Ellie Ewing, whose address is P.O. Box 123, South Fork, Texas, 73020, and whose interest in the estate of the above-decedent is that of devisee and surviving spouse, prays by and through her undersigned counsel, that a certain written instrument be admitted to probate as the Last Will of the decedent, without appointment of personal representative or administration of estate. The facts, so far as they are known to or can reasonably be ascertained by petitioner, are:

- a. Decedent: The decedent, John Ross “Jock” Ewing, aged 79 years, who resided at the South Fork Ranch, South Fork, Texas, died at Cook Forth Worth Hospital, on March 25, 1985. Decedent owned certain real property located in White County, Arkansas.
- b. Proffered Will: The decedent left as his Last Will an instrument dated October 5, 1979, executed in Texas in accordance with Texas law. Due proof of the execution thereof in the manner required by law is made by notarized attestation clause in the decedent’s Last Will.

- c. Surviving Spouse, Heirs, and Devisees: The surviving spouse, heirs, and devisees of the decedent, and their respective ages, relationships to the decedent, and residence addresses are as follows:

Name	Age	Relationship	Address
Ellie Ewing	Adult	Surviving Spouse	South Fork Ranch, South Fork Texas
J.R. Ewing	Adult	Son	South Fork Ranch, South Fork Texas
Bobby Ewing	Adult	Son	South Fork Ranch, South Fork Texas
Gary Ewing	Adult	Son	South Fork Ranch, South Fork Texas

- d. Value of Estate: The probable value of the estate of the decedent is as follows:
- i. Real Property: Undetermined
 - ii. Personal Property: Undetermined
- e. Title to Property: The decedent's will should be admitted to probate as a muniment of title for the sole purpose of showing record title to the following described real property:

An undivided one half mineral interest to the SE/4 SE/4, Section 11, Township 12 North, Range 13 West, Searcy County, Arkansas.

WHEREFORE, petitioner prays this Court enter an Order determining the fact of the death of the decedent, that the proffered instrument was executed in all respects according to law when the testator was competent to do so and acting without undue influence, fraud, or restraint, has not been revoked, and is the decedent's Last Will, that there is no necessity for the appointment of a personal representative, or for

administration of the estate of the decedent; and admitting the decedent's Will to probate in Arkansas for the sole purpose of showing record title to the property described herein.

Respectfully submitted,

Attorney

By: _____
Attorney, Bar No. 1234567
Attorney for Petitioner

VERIFICATION

I, Ellie Ewing, Petitioner in the hereinabove entitled matter, do hereby swear, affirm and verify that I have read the entire Petition set forth above and I do hereby swear, affirm and verify that the allegations contained therein are true and correct to the best of my knowledge and belief.

Ellie Ewing

STATE OF TEXAS

COUNTY OF TARRANT

Subscribed and sworn to before me this ____ day of _____, 200_.

Notary Public

My Commission Expires: _____

-seal-

**Errata Sheet for Basic Arkansas Intestate Succession, Rights of Surviving Spouses,
And Related Curative Techniques for Lawyers and Landmen.**

Note 16

This note should read:

See Exhibit A, supra. The only instance where collateral heirs are favored over a surviving spouse in the current Arkansas scheme is where the decedent had no issue and there is either no surviving spouse or a surviving spouse of less than 3 years.

Note 25

The second to last sentence of this note should read:

Prior to this act, the statutes consistently required the father of the illegitimate child to marry the mother of the illegitimate child, and the father had to perform some act acknowledging the paternity of the illegitimate child.

Note 76

Add to Note 76:

The author does not intend to suggest that all ancillary probates are eligible for administration in Arkansas. A fair reading of the statute limiting the time period for the probate of a will is that it prohibits administration (not probate) of foreign wills after 5 years even though there was a valid probate in another state. There are strong practical and policy arguments against reading the statute this way, but many probate attorneys and judges adopt this construction of the statute. There is no appellate court guidance on this subject in Arkansas.

Exhibit E:

It is unclear whether this petition would stand because it seeks administration more than 5 years past the decedent's death, so please presume the decedent died in the last 5 years rather than 1985. *See* note 76.

Exhibit F:

This style of this probate petition should read:

In The Circuit Court Of Searcy County, Arkansas